

# OPERATOR ROUTINE MAINTENANCE

## Daily

- › Clean the Print Heads (do this first thing before your shift).
- › Replace the Dust Extractor Bags if full.
- › Inspect the Waste and Extended Waste Conveyors for any hindrance, belt damage or incorrect tracking.
- › Blow down the Saw Chamber and the Feeders.
- › Be on the look-out for anything that appears incorrect or loose.
- › Clean the floor around the machine.

## Weekly

- › Clean and inspect the Saw Chamber Door.
- › Inspect the Follower for any loose, damaged or faulty components.
- › Inspect and clean the Feeder Sensors.
- › Inspect and clean the Feeder Drive Rollers (steel bottom ones).
- › Shake the dust out of the top Dust Filter Bags.
- › Blow down the Saw Chamber (including the top) and the Feeders.

## Monthly

- › Grease all bearings (Y and Z-axes, Feeders, AIT, Follower, Printer, OFK and Waste Conveyors) and ball screw nuts (Y and Z-axes).
- › Check the AIT chain tensions (4 side transfer chains and 1 roller conveyor chain).
- › Clean any grime off the Follower's horizontal steel linear rail using a small amount of WD40 on a rag. (only applicable to pre-September 2016 non-Rexroth Followers – See the difference on p. 27.)
- › Inspect the Feeder Nylon Rollers (4 top and 12 side).
- › Clean the Fan Filters and Electrical Cabinets.
- › Blow down the entire machine.

**This page is intentionally left blank.**

# ISOLATION PROCEDURES



**Note:** the isolation procedures below are to be followed when required by a maintenance operation.

## Electrical isolation

### Saw

1. Save any open files and close Simple.
2. Shut down the PC (Start Menu > Shut down).
3. Hold down the red STOP button on the operator console for 3 seconds.
4. Press the E-stop button on the operator console.
5. Remove all timber from the saw.



**Note:** make sure the PC is now completely off and the monitor is blank before continuing.

6. Turn off the electrical isolation switch on the front of the saw.
7. Lock out / tag out the electrical isolation switch.

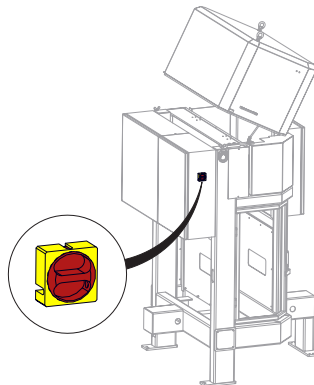

## Dust Extractor (if required)

1. Press the red STOP button on the dust extractor control panel.
2. Press the E-stop button on the dust extractor control panel.

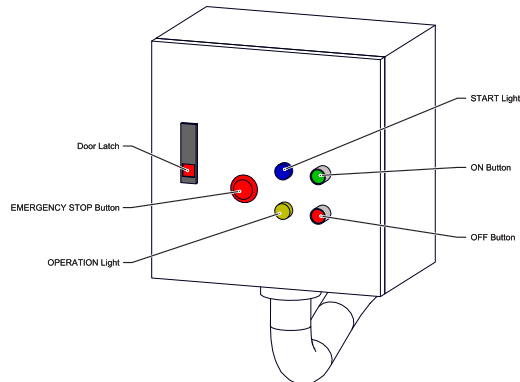

3. Isolate the incoming power supply to the dust extractor.
4. Lock out / tag out the incoming power supply to the dust extractor.

## Pneumatic isolation

1. Turn off the pneumatic isolation switch on the pneumatic unit.
2. Lock out / tag out the pneumatic isolation switch.

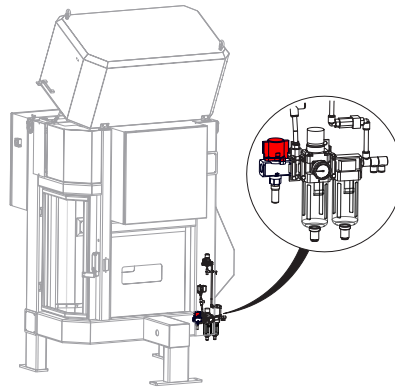

## DAILY

### Clean the print heads

#### WHAT YOU NEED

**Safety Equipment:**

- Standard Personal Protective Equipment



**Other Equipment:**

- Damp lint free cloth
- Dry lint free cloth



#### Regular Clean

1. Home the saw to ensure the printer is in the full up position.
2. Fold a piece of paper towel to a small square, soak with water and squeeze slightly to stop dripping.
3. Wipe each protruding print head with the wet paper towel and ensure there is a new and strong double black line on the paper towel from the print head each time.

#### Thorough Clean (if issue remains with particular print heads)

1. Lift the printer cover.
2. Make sure the status of both print modules reads "Case open" in the [plate marking control panel](#).
3. Open the retention latch for all print heads, not forgetting the side print heads.
4. Remove each print head one by one, and clean by dabbing and wiping firmly with a damp lint free cloth. You should get two solid lines of ink.



**CAUTION**

Do not shake the print heads at any point or this can permanently damage them.

5. Make sure no ink or grime is on the electrical contacts behind the print heads. Wipe clean with a **dry** lint free cloth if required.

6. Refit each print head and close the retention latches fully.



**Note:** If you have trouble closing a retention latch, re-seat the print head to make sure it is inserted correctly.

7. Close the printer cover.

## Testing

1. Make sure the status indicators of all print heads are green in the plate marking control panel.
2. If the status indicator of any print head is red or yellow after a couple of minutes, re-clean using the above procedure.
3. If a print head is still showing a red or yellow status indicator, replace it with a new one.
  - ↳ If the problem remains in the same slot, the issue is not the print head. Call Vekta for assistance solving this issue.
  - ↳ If the problem follows the print head, then the print head is faulty. Replace it with a new one and test again.

## Inspect and replace the dust extractor bags

### WHAT YOU NEED

**Tools:**

- Adjustable Spanner

**Spare Parts:**

- Dust Extractor Bags - ME1192

**Safety Equipment:**

- Standard Personal Protective Equipment



### Inspection and replacement

1. Press the E-stop button on the operator console.
2. Isolate the dust extractor (see page 4).
3. Visually inspect the dust extractor for any signs of damage.
4. Shake the dust out of the top dust filter bags (if fitted).
5. Operate the cleaning mechanism on the side of the dust extractor to clean the cartridge filters (if fitted).
6. Shake the dust extractor bags to remove excess dust.
7. Use an air gun to blow down the dust extractor.
8. Unlatch the locking strap on any bag that is full and needs replacing.
9. If bags are filling unevenly, adjust the baffles that are used to control the dust flow to each bag:
  - a. Use a spanner to loosen the exterior nuts that secure the baffle inside the dust extractor above the bag.
  - b. Adjust to direct more or less dust into the bag in question.
  - c. Re-tighten the nuts to secure the baffle in place again.
10. Install new bags using the locking strap, making sure the new bag is in good condition.

### Testing

1. Turn power back on for the dust extractor.
2. Release the E-stop button on the dust extractor control panel.
3. Release the E-stop button on the operator console.

4. Rehome the saw.
5. Using the Manual Mode window, make sure the dust extractor turns on normally and the bags are filling with air properly.



# Inspect and track the waste and extended waste conveyor belts

## WHAT YOU NEED

### Tools:

- Combination Spanner Set
- Allen Key Set



### Safety Equipment:

- Standard Personal Protective Equipment



### CAUTION

When using the manual mode, make sure that everything and everyone is clear of moving parts to prevent damage or injuries.

## Inspection

1. Inspect each one of the waste and extended waste conveyors and make sure it is clear of any wedged offcuts or excess build-up.
2. Using the Manual Mode window, run the waste conveyors forwards.
3. Check the condition of the entire belt on each waste conveyor while it is running, watching for tears and frayed edges.



**Note:** if the belt is damaged, it should be replaced during the service.

4. Check the tracking of the belt, watching if it runs to one side of the rollers. If the tracking needs to be adjusted, follow the procedure below.

## Tracking

1. Press the E-stop button on the operator console.
2. Extend the M8 tensioning bolts on the bearing blocks to make sure they are tight against the push blocks.
3. Loosen the three cap head bolts slightly to allow the appropriate bearing blocks to be adjusted.

4. Slightly extend or retract the tensioning bolts to adjust the roller alignment.

**E X A M P L E**

If the belt needs to move left, extend the right bearing and/or retract the left bearing (ensuring you leave the belt tensioned properly).

5. Tighten the three cap head bolts on each bearing block.
6. Tighten the locknut on the tensioning bolts.
7. Release the E-stop button on the operator console.
8. Rehome the saw.
9. Using the Manual Mode window, run the waste conveyors forwards to check the tracking.
10. Repeat the tracking procedure if needed.

## Daily clean

### WHAT YOU NEED

**Tools:**

- Air Gun



**Safety Equipment:**

- Standard Personal Protective Equipment
- Eye and Hear Protection



1. Press the E-stop button on the operator console.
2. Start the dust extractor manually by pressing the ON button on the dust extractor control panel.
3. Blow down the saw chamber, starting at the top and working your way down. Make sure you don't miss any of the following areas:
  - » on top of the Y-axis assembly
  - » through the centre of the C-axis
  - » on top of the C-axis
  - » around the B-axis and saw blade



**CAUTION**

**SHARP BLADE:** Keep clear of the saw blade while working inside the saw chamber.

4. Blow down the feeders, ensuring you remove any swarf from the following areas:
  - » on top of the side clamp cylinders
  - » around the sides of the chambers
  - » around the six yellow photoelectric sensors in each feeder
  - » under the feeders



**Note:** reach up under the side feeder guards and make sure to remove any dust or swarf that may interfere with the operation of the drive rollers or pop-up encoders.

5. Gently blow down the top of the printer.



**CAUTION**

Do not blow air onto the print heads.

6. Stop the dust extractor manually by pressing the OFF button on the dust extractor control panel.
7. Release the E-stop button on the operator console.

8. Rehome the saw.
9. Using the Manual Mode window, start the waste conveyor forwards to remove all the dust from the bottom of the saw chamber.

## General inspection

### WHAT YOU NEED

Standard Personal Protective Equipment



- › Inspect the saw chamber:
  - › Look for loose or damaged sensors or cables.
  - › Look for hydraulic oil around the B-axis, which may indicate a leak.
- › Inspect both feeders:
  - › Look for loose, misaligned or damaged photoelectric sensors.
  - › Look for damage on the drive or nylon rollers.
- › Inspect the Automatic Infeed Table (AIT):
  - › Look for damage to the re-ref sensors.
  - › Make sure the table sits above the side transfer chains (when in the up position).
- › Inspect the follower:
  - › Look for damage along the edge of the timing belt.
  - › Look for damage to the sensor array.
- › Inspect the side transfer chains:
  - › Look for damaged or misaligned chains.
  - › Inspect the two gap detection sensors for damage.
  - › Make sure the shaft is not damaged.
- › Inspect the printer:
  - › Lift the printer cover and look for loose ribbon cables on the top and side print heads.
  - › Make sure the printer encoder is secure and not damaged.
- › Inspect the Outfeed Kickoff Table (OFK).

**This page is intentionally left blank.**

## WEEKLY

### Clean and inspect the saw chamber door

#### WHAT YOU NEED

**Safety Equipment:**

- Standard Personal Protective Equipment

**Other Equipment:**

- Microfibre cloth
- Warm soapy water or Windex



1. Using the Manual Mode window, move the saw blade to the back of the saw chamber.
2. Press the E-stop button on the operator console.
3. Open the saw chamber door.
4. Start the dust extractor manually by pressing the ON button on the dust extractor control panel.
5. Blow off any loose dust or swarf on and around the door.
6. Stop the dust extractor manually by pressing the OFF button on the dust extractor control panel.
7. Clean off any remaining dust and built-up grime with the microfibre cloth and warm soapy water. You may soak problem areas for several minutes if required.

**CAUTION**

- Do not use anything but a microfibre cloth or this will scratch the surface of the door and cause it to become cloudy.
- Do not use harsh cleaning products or strong solvents (e.g. acetone) or this will cause the door to become cloudy, brittle and more susceptible to damage.

8. Perform a thorough visual inspection for any bubbles or cracks, paying close attention to the bend in the door.



**Note:** Please contact Vekta Automation immediately if any defects are found in the door. It will need to be replaced as soon as possible.

9. Shut the saw chamber door.
10. Release the E-stop button on the operator console.

## Inspect the follower

### WHAT YOU NEED

Standard Personal Protective Equipment



### Inspection

1. Press the E-stop button on the operator console.
2. Perform the following checks:
  - » Make sure the follower carriage is secure by hand (rock the follower side to side and up and down).
  - » Make sure the follower has no apparent loose components (e.g. paddle, sensor bracket, etc.).
  - » Inspect the follower timing belt for any signs of damage (e.g. fraying, nicks or cuts).
  - » Inspect the follower drag chain, cables and pneumatic hoses for any damage, leaks, nicks or cuts.
  - » Inspect the follower home sensor for any signs of damage.
  - » Inspect the follower end stops for any signs of damage or bent brackets.
3. Release the E-stop button on the operator console.
4. Power the machine back on by pressing the green CONTROL button on the operator console.
5. On the sensor array, make sure the green power LED of each sensor is on and their orange sensing LED turns on when moving a piece of timber in front of them.



**Note:** contact Vekta Automation if any of the checks do not look or feel correct.

### Testing

- › Make sure the follower rehomes correctly.
- › Make sure the follower slows down before contacting the timber while cutting.



## Inspect and clean the feeder sensors

### WHAT YOU NEED

#### Tools:

- Allen Key Set
- Security Torx Key Set
- Small Flat Head Screwdriver
- Small Phillips Head Screwdriver
- Loctite Low Strength Threadlocker



#### Spare Parts:

- Banner Laser Emitter - EL1023 (if needed)
- Banner Receiver - EL1024 (if needed)
- Metal Pinhole Mask - EL1022 (if needed)



#### Safety Equipment:

- Standard Personal Protective Equipment



#### Other Equipment:

- Damp cloth



## Inspection and cleaning

1. Remove both feeder transparent covers.
2. Perform the following checks:
  - » Inspect the feeder sensors for any initial signs of damage or misalignment.
  - » Make sure the green power LED on each emitter and receiver is on.
  - » Check the strength and alignment of the laser beams on the receiver side by placing a thin strip of timber in front of each emitter. The beam should be clearly visible and roughly in the centre of the receiver.
  - » Make sure the orange sensing LED on each receiver turns on when the beam is interrupted.
  - » Make sure there is a metal pinhole mask fitted to the first emitter on the infeed feeder (farthest from the saw chamber) and to the middle emitter on the outfeed feeder.
3. If any of the checks are not met, **press the E-stop button on the operator console** and perform the following tasks accordingly:
  - » Replace any damaged or faulty emitters and receivers with spare ones. Apply a small amount of Loctite on the mounting bolts.

- » If the beam is dull, clean the face of the emitter with a damp cloth. Remove any fitted mask if necessary and refit after cleaning. If this does not help, replace the emitter with a spare one.
  - » If the beam is off centre, adjust the alignment of the emitter.
  - » If any metal pinhole mask is missing, install a spare one.
- 4.** Refit both feeder transparent covers.

## Testing

- 1.** Release the E-stop button on the operator console.
- 2.** Feed a long length of timber into the saw by hand and make sure the "eye" feeder indicators in the monitoring panel turn grey when the beam is interrupted.

## Inspect and clean the feeder drive rollers

### WHAT YOU NEED

**Tools:**

- Security Torx Key Set
- Flat Head Screwdriver
- Air Gun



**Safety Equipment:**

- Standard Personal Protective Equipment
- Safety Gloves



**Other Equipment:**

- Wire brush



## Inspection and cleaning



**CAUTION**

**PINCH POINT:** Wear safety gloves and rotate the rollers very slowly.

1. Isolate the saw electrically (see page 3).
2. Remove both feeder transparent covers.
3. Inspect the drive rollers for any signs of damage and make sure they run freely.



**Note:** contact Vekta Automation if any roller needs to be replaced.

4. With a wire brush, remove any timber shavings and build-up caught in the drive roller knurls.



**Note:** where the wire brush is not sufficient, a flat head screwdriver can be used.

5. Carefully rotate the drive rollers and continue cleaning until all timber shavings and build-up are removed.
6. Blow down the feeders around each drive roller.
7. Refit both feeder transparent covers.

## Testing



### CAUTION

When using the manual mode, make sure that everything and everyone is clear of moving parts to prevent damage or injuries.

1. Turn on the electrical isolation switch on the front of the saw.
2. Release the E-stop button on the operator console.
3. Rehome the saw.
4. Open Simple.
5. Using the Manual Mode window, operate the drive rollers in both directions.

## Weekly clean

### WHAT YOU NEED

**Tools:**

- Air Gun



**Safety Equipment:**

- Standard Personal Protective Equipment
- Eye and Hear Protection



**Other Equipment:**

- Step Ladder



1. Using the Manual Mode window, move the Y-axis to the middle position and the Z-axis to the lowest position.
2. Press the E-stop button on the operator console.
3. Open up the dome.



**Note:** remove any blocks of wood that may have been thrown up.

4. Start the dust extractor manually by pressing the ON button on the dust extractor control panel.
5. Blow down the saw chamber, starting at the top and working your way down. Make sure you don't miss any of the following areas:
  - » on top of the Z-axis assembly and cable tray
  - » behind the Y-axis assembly and on top of the cable chain



**Note:** Pay particular attention to dust accumulating on top of the lower section of the cable chain. This needs to be cleaned thoroughly.

- » on top of the Y-axis assembly
- » through the centre of the C-axis
- » on top of the C-axis
- » around the B-axis and saw blade



**CAUTION**

**SHARP BLADE:** Keep clear of the saw blade while working inside the saw chamber.

6. Blow down the feeders, ensuring you remove any swarf from the following areas:
  - » on top of the side clamp cylinders
  - » around the sides of the chambers
  - » around the six yellow photoelectric sensors in each feeder
  - » under the feeders



**Note:** reach up under the side feeder guards and make sure to remove any dust or swarf that may interfere with the operation of the drive rollers or pop-up encoders.

7. Gently blow down the top of the printer.



**CAUTION**

Do not blow air onto the print heads.

8. Stop the dust extractor manually by pressing the OFF button on the dust extractor control panel.
9. Close the dome.
10. Release the E-stop button on the operator console.
11. Rehome the saw.
12. Using the Manual Mode window, start the waste conveyor forwards to remove all the dust from the bottom of the saw chamber.

# MONTHLY

## Greasing

### WHAT YOU NEED

**Tools:**

- Allen Key Set
- Security Torx Key Set
- Flat Head Screwdriver
- Grease Gun - ME1122
- EPL 2 Lithium Grease - ME1123



**Safety Equipment:**

- Standard Personal Protective Equipment



**Other Equipment:**

- Step Ladder
- Rags



**Note:** A multipurpose high pressure lithium-based grease is required for all linear bearings and ball screw nuts (Castrol Spheerol EPL 2 recommended). The same can be used for the other bearings but any lithium-based grease will be sufficient.

## Grease the Y and Z-axes



**CAUTION**

When using the manual mode, ensure the following:

- The appropriate speed slider is set to a very slow speed.
- Everything and everyone is clear of moving parts to prevent damage or injuries.

1. Using the Manual Mode window, move the Y-axis to the middle position and the Z-axis to the lowest position.
2. Open up the dome.
3. Remove the front and rear frame covers, along with the front and rear end covers of the Y-axis assembly.

4. Using the Manual Mode window, slightly raise the Z-axis, then move the Y-axis across its range of motion to remove the seven bolts that hold the centre brush cover of the Y-axis assembly, and remove the centre brush cover.
5. Using the Manual Mode window, move the Y-axis to the forwardmost position.
6. Apply 2-3 pumps of grease to each of the six grease nipples located on top of the saw and the four grease nipples on the Y-axis linear bearings.

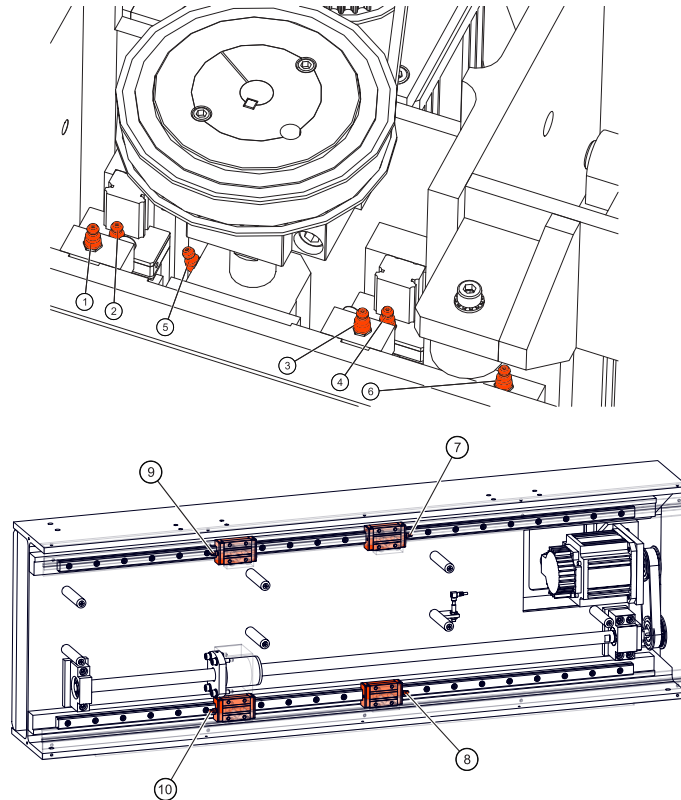

7. Using the Manual Mode window, move the Y and Z-axes to the middle position.
8. Apply 2-3 pumps of grease again to the same grease nipples.
9. Using the Manual Mode window, move the Y-axis to the rearmost position and the Z-axis to the highest position.
10. Apply 2-3 pumps of grease again to the same grease nipples.
11. Move the Y and Z-axes several times across their entire range of motion.
12. Using the Manual Mode window, move the Y-axis across its range of motion to refit the centre brush cover on the Y-axis assembly and tighten the seven bolts that hold it in place.
13. Refit the front and rear frame covers, along with the front and rear end covers of the Y-axis assembly.
14. Using the Manual Mode window, move the Y-axis to the middle position and the Z-axis to the lowest position.
15. Close the dome.



## Grease the feeders

1. Press the E-stop button on the operator console.
2. Remove the side feeder guards on both sides of each feeder.
3. Apply 2-3 pumps of grease to the eight grease nipples on the drive roller bearings.



**Note:** you may need to get under each feeder to reach the four drive roller bearings closest to the saw chamber.

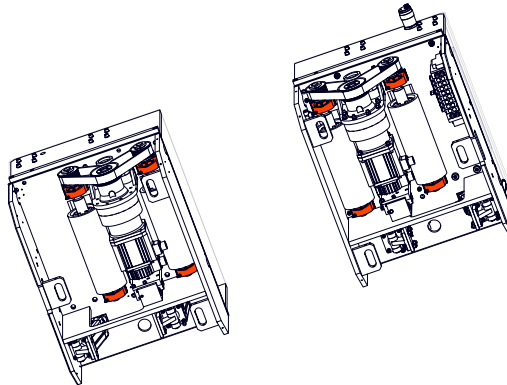

4. Apply 2-3 pumps of grease to the two grease nipples on the linear bearings of the pop-up encoders.



**Note:** when a follower is fitted, a pop-up encoder is present on the outfeed feeder only.

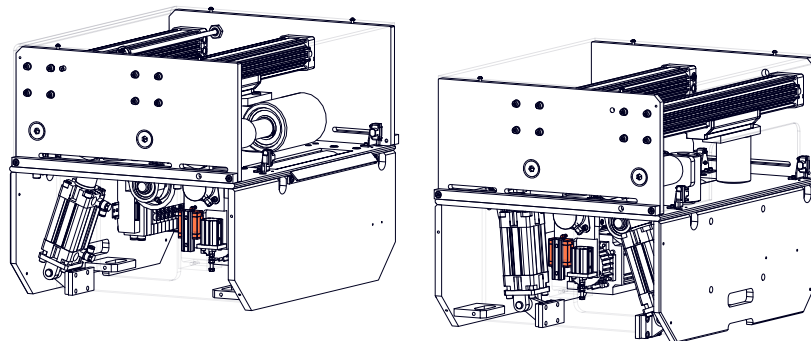

5. Apply 2-3 pumps of grease to the four grease nipples on the top clamp knuckles (machines from late 2016 onwards).
6. Refit the side feeder guards.
7. Release the E-stop button on the operator console.

## Grease the AIT

1. Press the E-stop button on the operator console.

2. Apply 2-3 pumps of grease to the three grease nipples on the roller bearings of the side transfer legs.

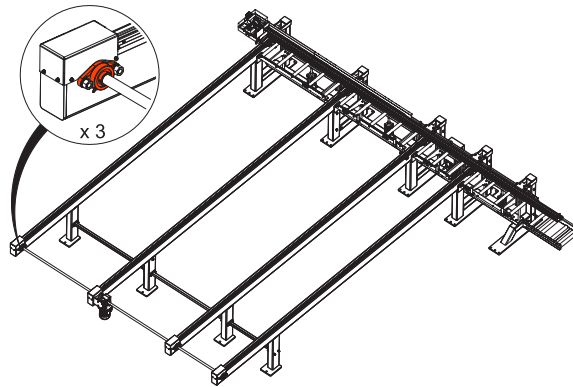

3. Apply 2-3 pumps of grease to the eight grease nipples on the linear bushings at the rear of the AIT.

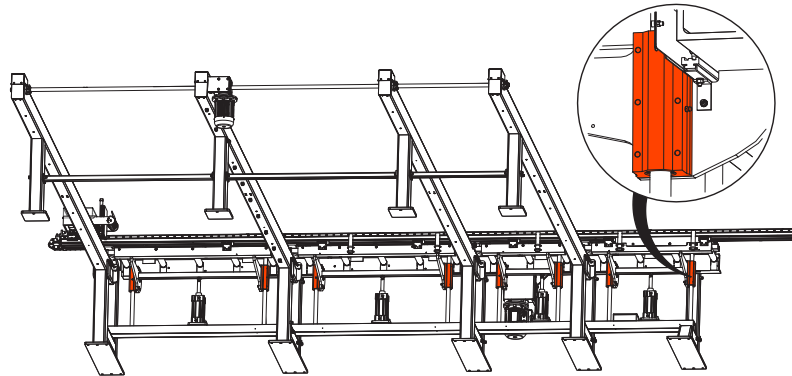

4. Release the E-stop button on the operator console.

## Grease the follower

1. Rehome the saw if not already in the home position (follower farthest from the saw chamber).
2. *Old follower (manufactured prior to September 2016):* Apply 1 pump of grease to the two grease nipples on the carriage linear bearings.  
*New follower (manufactured from September 2016):* Apply 1 pump of grease to the grease nipple on the shuttle plate.

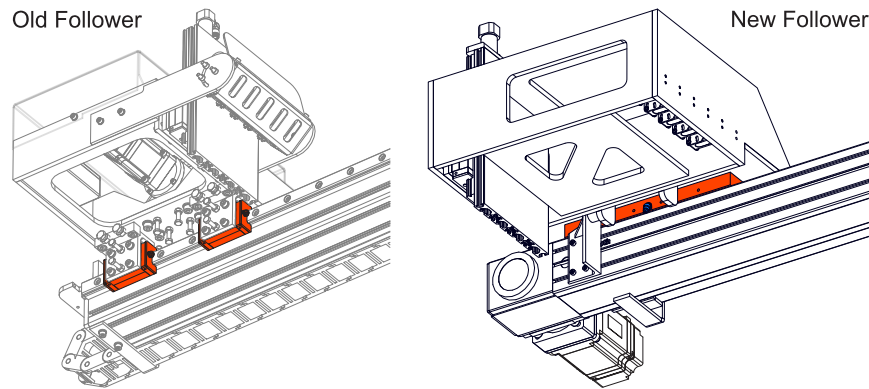

3. Start a rehoming cycle then press the red STOP button on the operator console when the follower is half-way up the rail.
4. Apply 1 pump of grease again to the same grease nipple(s).
5. Perform 3 rehoming cycles to distribute the grease along the follower rail.
6. Apply 2-3 pumps of grease to the two grease nipples on the paddle linear bearings.

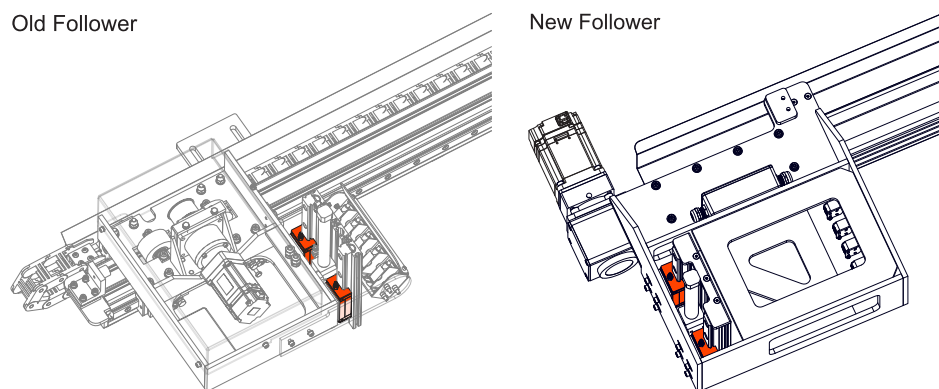

7. Wipe off any excess grease.

## Grease the P3 printer

1. Press the E-stop button on the operator console.
2. Lift the printer cover.
3. Apply 2-3 pumps of grease to the two grease nipples on the carriage linear bearings.

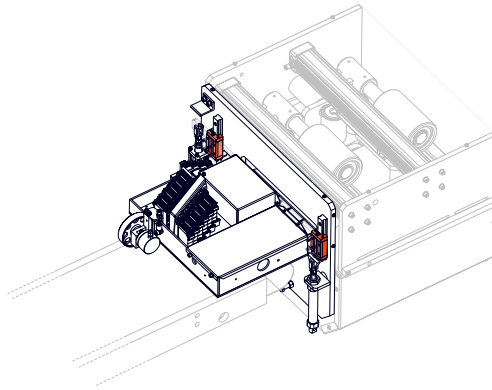

4. Close the printer cover.
5. Release the E-stop button on the operator console.

## Grease the OFK

1. Press the E-stop button on the operator console.
2. Apply 2-3 pumps of grease to the six grease nipples on the conveyor roller bearings.

 **Note:** you may need to lift the printer cover to reach the two conveyor roller bearings closest to the saw chamber.

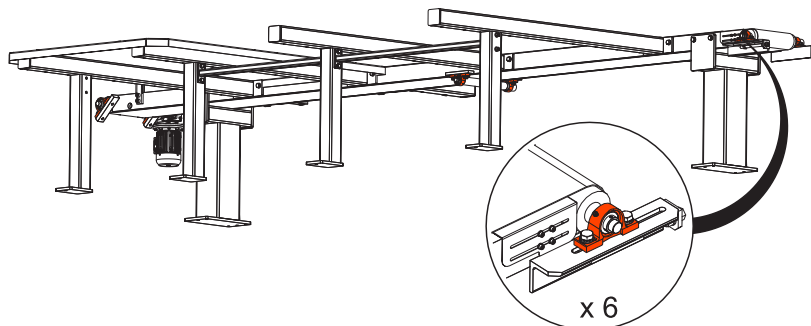

3. Release the E-stop button on the operator console.

## Grease the waste and extended waste conveyors

1. Press the E-stop button on the operator console.
2. Apply 2-3 pumps of grease to the four grease nipples on the roller bearings of the waste conveyor under the saw chamber.

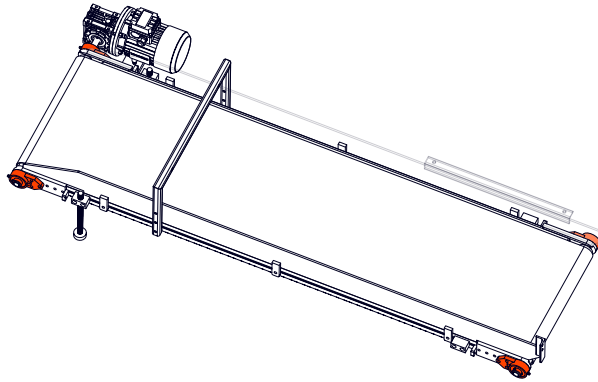

3. Apply 2-3 pumps of grease to the grease nipples (four per conveyor) on the roller bearings of the extended waste conveyor(s).
4. Release the E-stop button on the operator console.

## Testing

1. Make sure all axes rehome correctly.
2. Start a cutting sequence with normal sticks of timber from an optimised job file and make sure everything runs smoothly.

## Check the AIT chain tensions

### WHAT YOU NEED

**Tools:**

- 24-mm Combination Spanner



**Safety Equipment:**

- Standard Personal Protective Equipment
- Safety Gloves



### Check and correct the chain tension on the side transfer legs

1. Press the E-stop button on the operator console.
2. In the centre of each side transfer legs, lift up the chain to test the tension.



**Note:** there should not be more than 75 mm of deflection in the chain.

3. Inspect the chain for signs of wear and for any rubbish or bits of timber that may cause the side transfer to pinch.
4. If a side transfer chain is loose, do the following:

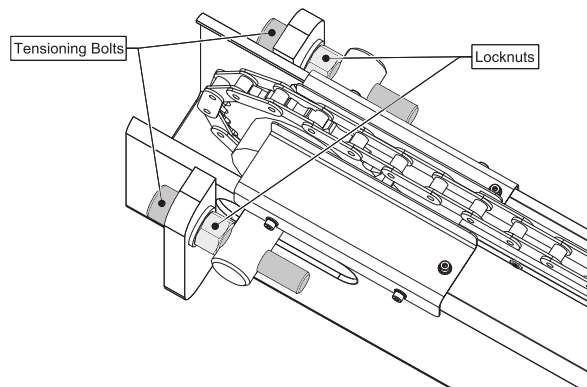

- a. Loosen the locknut on both tensioning bolts at the end of the side transfer leg (roller conveyor side).
- b. Evenly tighten both tensioning bolts to tension the chain.
- c. Check the chain tension after each small adjustment.
- d. Tighten the locknut on both tensioning bolts.

### Check the chain tension on the infeed roller conveyor

1. Press the E-stop button on the operator console.

2. Rotate one conveyor roller back and forth to feel for any excessive backlash.



**Note:** there should not be more than 1 or 2 mm of backlash.

3. Inspect the chain for signs of wear and for any rubbish or bits of timber that may cause the roller conveyor to pinch.
4. If the roller conveyor chain is loose, do the following:
  - a. Loosen the AIT motor mounting bolts.
  - b. Adjust the chain tension by lowering or raising the AIT motor slightly.
  - c. Check the chain tension after each small adjustment.
  - d. Tighten the AIT motor mounting bolts.



**Note:** you may need to contact a Vekta Automation for assistance in tensioning the chain.

## Testing



### CAUTION

When using material handling in the manual mode, make sure that everything and everyone is clear of moving parts to prevent damage or injuries.

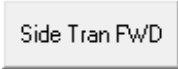
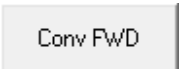
1. Release the E-stop button on the operator console.
2. Rehome the saw.
3. Open Simple.
4. In the Material Handling window, click  to operate the side transfer legs and check for any misalignment.
5. Click  under AIT Infeed Control to operate the infeed roller conveyor and check for any misalignment.

## Inspect the feeder nylon rollers

### WHAT YOU NEED

**Tools:**

- Security Torx Key Set



**Safety Equipment:**

- Standard Personal Protective Equipment



**Note:** there are four side fence rollers, two side clamp rollers and two top clamp rollers in each feeder, which makes a total of 16 nylon rollers.

## Inspection

1. Using the Manual Mode window, move the saw blade to the back of the saw chamber.
2. Isolate the saw electrically (see page 3).
3. Remove both feeder transparent covers.
4. Inspect the nylon rollers for any signs of damage, wear or flat spots.
5. Gently move the 12 side rollers up and down, and the four top rollers sideways to make sure they have a small amount of play.
6. Make sure they run freely and there is no sign of sticking.



**Note:** If any roller or roller bearing needs to be replaced, contact Vekta Automation.

7. Refit both feeder transparent covers.

## Testing



**CAUTION**

When using the manual mode, make sure that everything and everyone is clear of moving parts to prevent damage or injuries.

1. Turn on the electrical isolation switch on the front of the saw.
2. Release the E-stop button on the operator console.
3. Rehome the saw.
4. Open Simple.



**5.** Using the Manual Mode window, feed in a stick of timber and make sure it feeds correctly.

## Clean the fan filters and electrical cabinets

### WHAT YOU NEED

**Tools:**

- Large Flat Head Screwdriver
- Air Gun



**Safety Equipment:**

- Standard Personal Protective Equipment



**Other Equipment:**

- Electrical cabinet door key



1. Isolate the saw and the dust extractor electrically (see page 3).
2. Blow air towards the ground for several seconds to make sure there is no moisture left in the air gun.
3. Using a flat head screwdriver, remove the front covers off all fan vents to access the fan vent filters.
4. Blow all dust out of the filters and vents.
5. Refit all vent covers.



**Note:** make sure the filter is flat in the vent covers.

6. Open each electrical cabinet and inspect for any build-up of dust.
7. If there is excessive dust, gently blow **dry** air in and around the cabinet from top to bottom.



**CAUTION**

Do not blow air directly onto exposed electrical components.

8. Gently blow the dust off the electrical fans.
9. Once all dust has been removed, close and lock each electrical cabinet.

## Monthly clean

### WHAT YOU NEED

**Tools:**

- Security Torx Key Set
- Allen Key Set
- Air Gun



**Safety Equipment:**

- Standard Personal Protective Equipment
- Eye and Hear Protection



**Other Equipment:**

- Step Ladder



1. Using the Manual Mode window, move the Y-axis to the middle position and the Z-axis to the lowest position.
2. Isolate the saw electrically (see page 3).
3. Open up the dome.
4. Remove the side feeder guards.
5. Remove the front and rear end covers of the Y-axis assembly.
6. Start the dust extractor manually by pressing the ON button on the dust extractor control panel.
7. Blow down the saw chamber, starting at the top and working your way down. Make sure you don't miss any of the following areas:
  - » on top of the Z-axis assembly and cable tray
  - » behind the Y-axis assembly and on top of the cable chain



**Note:** Pay particular attention to dust accumulating on top of the lower section of the cable chain. This needs to be cleaned thoroughly.

- » on top of the Y-axis assembly
- » through the centre of the C-axis
- » on top of the C-axis
- » around the B-axis and saw blade



**CAUTION**

**SHARP BLADE:** Keep clear of the saw blade while working inside the saw chamber.

8. Blow all dust and swarf out of the Y-axis assembly from front to rear.



**Note:** make sure to remove any dust or swarf that may interfere with the operation of the linear bearings or ball screw nut.

9. Blow down the feeders, ensuring you remove any swarf from the following areas:

- » on top of the side clamp cylinders
- » around the sides of the chambers
- » around the six yellow photoelectric sensors in each feeder
- » under the feeders



**Note:** make sure to remove any dust or swarf that may interfere with the operation of the drive rollers or pop-up encoders.

10. Gently blow down the top of the printer.



**CAUTION**

Do not blow air onto the print heads.

11. Stop the dust extractor manually by pressing the OFF button on the dust extractor control panel.

12. Refit the front and rear end covers of the Y-axis assembly.

13. Refit the side feeder guards.

14. Close the dome.

15. Turn on the electrical isolation switch on the front of the saw.

16. Release the E-stop button on the operator console.

17. Rehome the saw.

18. Open Simple.

19. Using the Manual Mode window, start the waste conveyor forwards to remove all the dust from the bottom of the saw chamber.

**This page is intentionally left blank.**

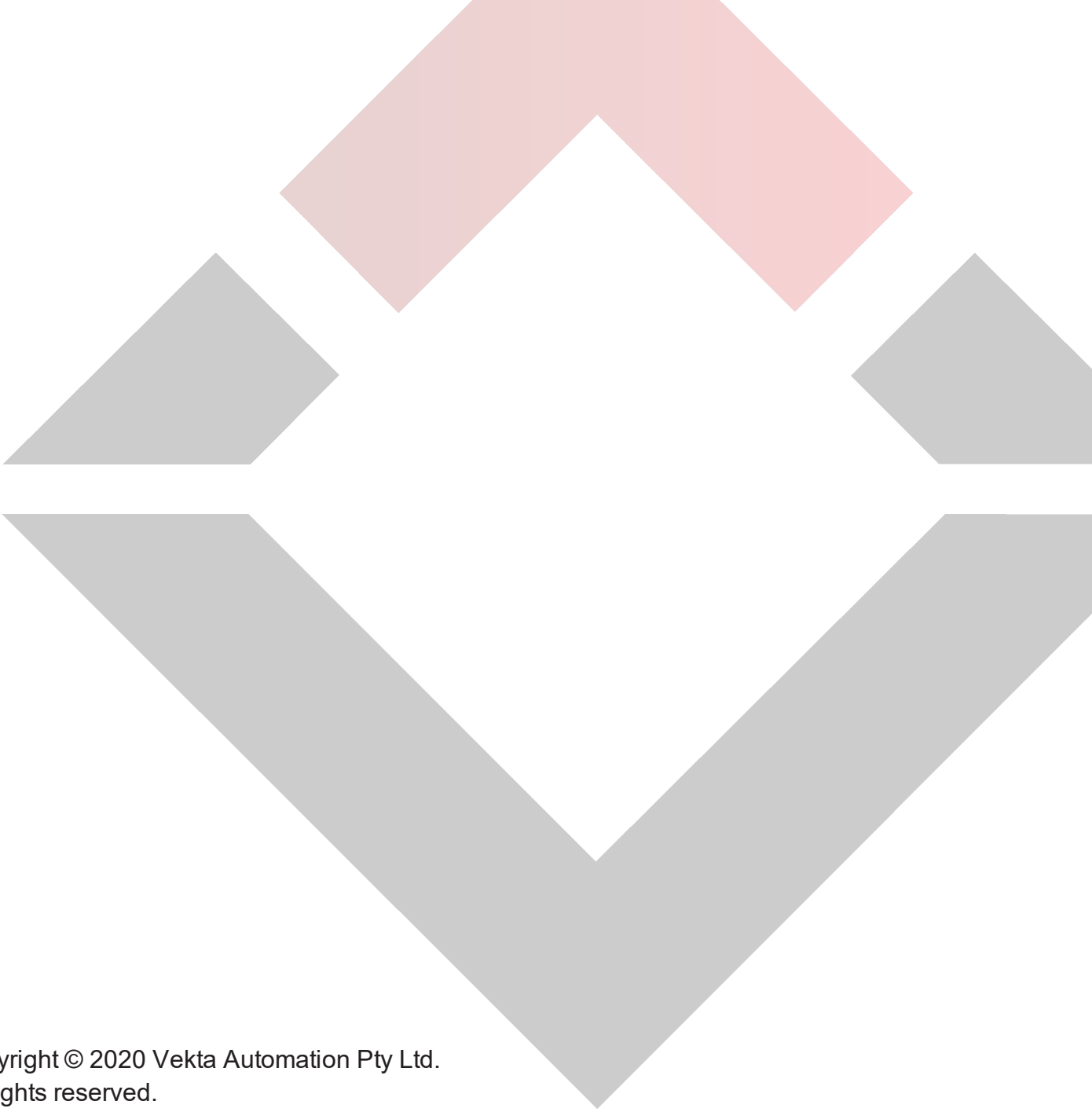

Copyright © 2020 Vekta Automation Pty Ltd.  
All rights reserved.

Information in this document is subject to change without notice. No part of this publication may be reproduced, stored in a retrieval system, or transmitted in any form or any means electronic or mechanical, including photocopying and recording for any purpose other than the purchaser's personal use without the written permission of Vekta Automation Pty Ltd.

Vekta Automation Pty Ltd  
85 Beringarra Avenue  
Malaga WA 6090  
+61 8 6117 0660